

MAXIM

MAX4188 Evaluation Kit

Evaluates: MAX4188/MAX4189

General Description

The MAX4188 evaluation kit (EV kit) simplifies evaluation of the MAX4188 triple, low-power, current-feedback amplifier. The MAX4188 amplifier is set to a gain of +2V/V. SMA connectors and 50Ω terminating resistors are included for 50Ω test equipment compatibility. For video test equipment compatibility, simply change the terminating resistors to 75Ω and change R_F and R_G resistors to the values shown in the MAX4188/MAX4189/MAX4190 data sheet.

The EV kit comes with the MAX4188 installed. To evaluate the MAX4189, order a free sample (MAX4189ESD), replace the MAX4188 with the MAX4189 on the EV board, and change the gain-setting and feedback resistors for unity gain as shown in the MAX4188/MAX4189/MAX4190 data sheet.

Component List

DESIGNATION	QTY	DESCRIPTION
C1, C4	2	10μF, 10V, 20% tantalum capacitors AVX TAJB106M010 or Sprague 293D106X0010B
C2, C5	2	0.33μF, 10% ceramic capacitors
C3, C6	2	0.01μF, 10% ceramic capacitors
R1–R6	6	49.9Ω, 1% resistors
RF1, RF2, RF3, RG1, RG2, RG3	6	390Ω, 1% resistors
IN1+, IN2+, IN3+, OUT1, OUT2, OUT3	6	SMA connectors
JU1, JU2, JU3	3	2-pin header
U1	1	MAX4188ESD
None	1	MAX4188 EV kit PC board
None	3	Shunts for JU1, JU2, JU3

Component Suppliers

SUPPLIER*	PHONE	FAX
AVX	(803) 946-0690	(803) 626-3123
Sprague	(603) 224-1961	(603) 224-1430

*Please indicate that you are using the MAX4188 when contacting these component suppliers.

Features

- ◆ Fast Enable/Disable Times (120ns/35ns)
- ◆ Very Low Switching Transient (45mVp-p)
- ◆ Single +5V or Dual ±5V Supply Operation
- ◆ 130MHz -3dB Bandwidth
- ◆ 350V/μs Slew Rate
- ◆ 70MHz -0.1dB Gain Flatness
- ◆ 0.04%/0.32% Gain/Phase Errors (R_L = 150Ω)
- ◆ Fully Assembled and Tested Surface-Mount Board

Ordering Information

PART**	TEMP. RANGE	IC PACKAGE
MAX4188EVKIT	-40°C to +85°C	14 SO

**To evaluate the MAX4189, request a MAX4189ESD sample.

Quick Start

The MAX4188 EV kit is fully assembled and tested. Follow these steps to verify board operation.

- 1) The circuit requires supply voltages of ±2.25V to ±5.5V. For evaluation purposes, connect a +5V supply to the pad labeled VCC and a -5V supply to the pad labeled VEE. Connect power-supply ground to the pad labeled GND.
- 2) Connect an output (OUT1–OUT3) to an oscilloscope input. Remove shunt from the corresponding jumper (JU1–JU3) to enable the selected amplifier.
- 3) Turn on the power supply. Apply a ±1.35V signal to the appropriate amplifier input (IN1–IN3). The 100Ω load (chosen for ease of evaluation) limits the output voltage range. Wider output voltage swings are achievable with lighter loads. See the MAX4188/MAX4189/MAX4190 data sheet.
- 4) Verify the output signal on the oscilloscope.



MAX4188 Evaluation Kit

Detailed Description

Setting the Voltage Gain

The gain of the MAX4188's amplifiers can be individually set by changing the appropriate feedback (RF) and gain-set (RG) resistors. For example, the gain of amplifier 1 can be set using resistors RF1 and RG1. Refer to the MAX4188/MAX4189 data sheet for recommended values.

Enable/Disable Control

The MAX4188 provides $\overline{\text{DISABLE}}$ pins to enable or disable each of the three outputs and isolate the amplifiers from the external inputs. Jumpers JU1–JU3 can be used to manually control each $\overline{\text{DISABLE}}$ pin. An external controller may also be used by connecting the controller to the appropriate disable pad ($\overline{\text{DISABLE}}_n$) and removing

the corresponding jumper shunt. The amplifiers default to the enable mode if the $\overline{\text{DISABLE}}$ pin is left floating/unconnected. For a single +5V supply or dual $\pm 5\text{V}$ supplies, the $\overline{\text{DISABLE}}$ inputs are CMOS-logic compatible. The logic threshold is $V_{CC} - 2.5\text{V}$.

Layout Considerations

The PC board layout has been optimized for high-speed signals and low distortion, with careful attention given to grounding, power-supply bypassing, and signal-path layout. The small, surface-mount, ceramic bypass capacitors (C2, C3, C5, C6) have been placed as close to the amplifier's supply pins as possible. Capacitance at the inverting input pins has been minimized by reducing the length and width of the input and feedback traces and by using 0805-size feedback and gain-set resistors.

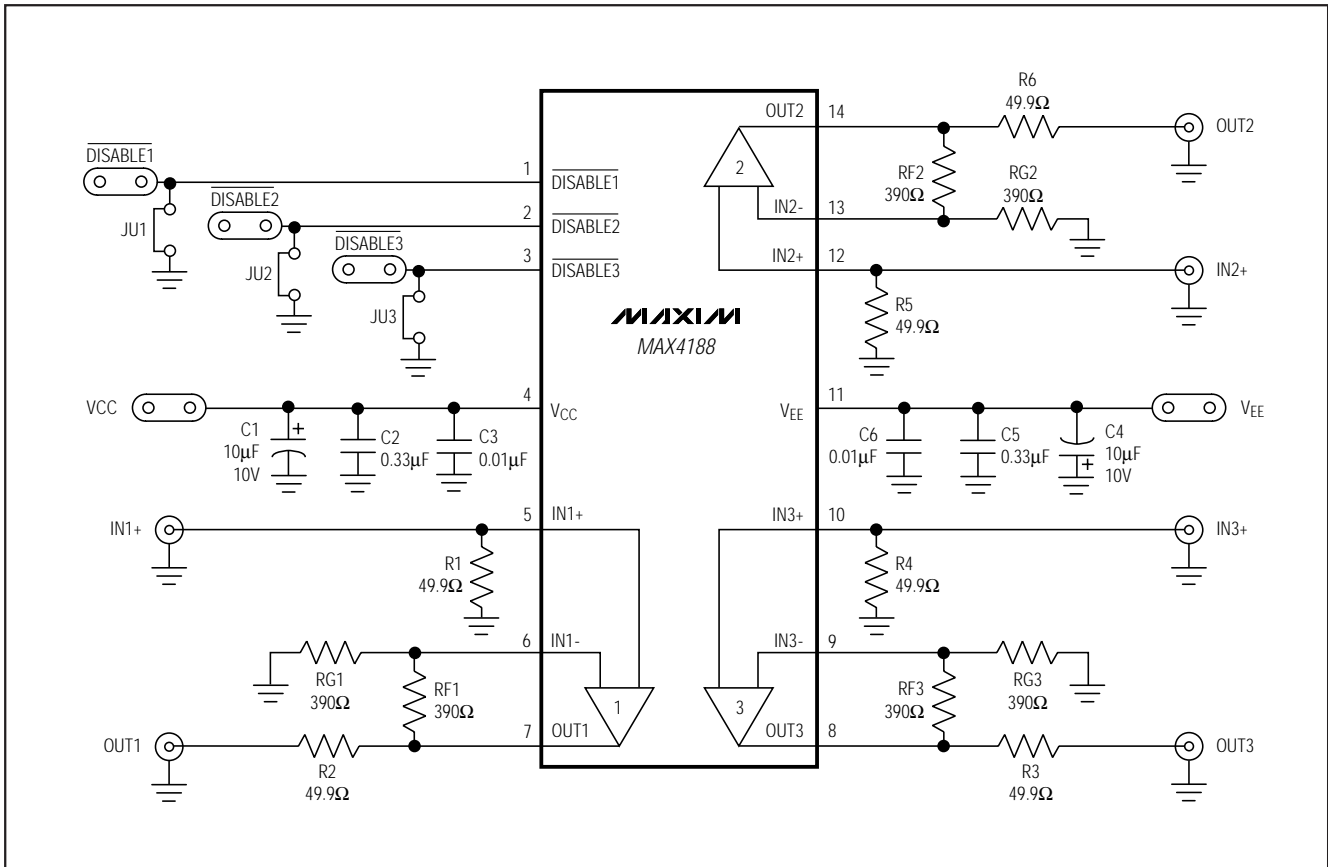

Figure 1. MAX4188 EV Kit Schematic

MAX4188 Evaluation Kit

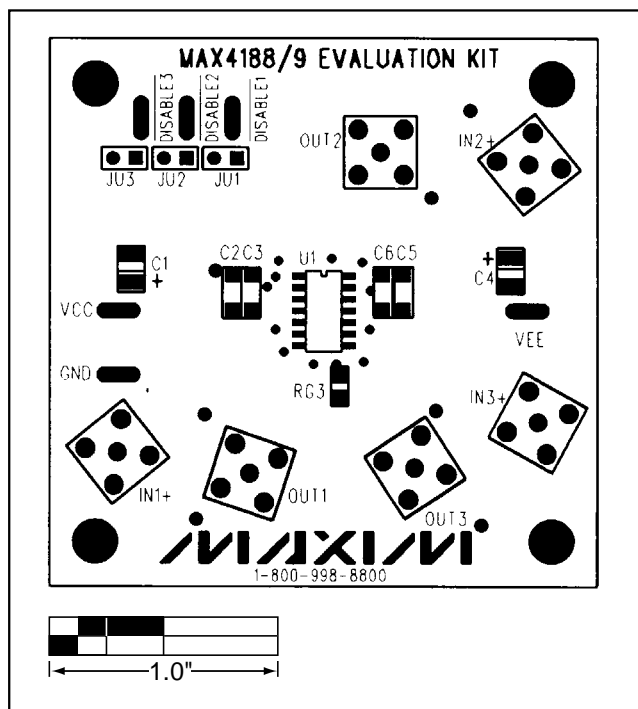

Figure 2. MAX4188 EV Kit Component Placement Guide—Component Side

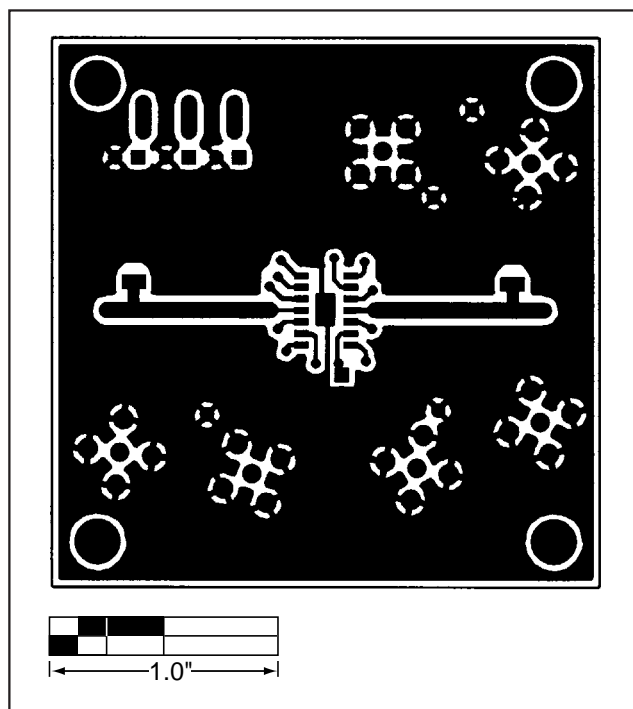

Figure 3. MAX4188 EV Kit PC Board Layout—Component Side

Evaluates: MAX4188/MAX4189

MAX4188 Evaluation Kit

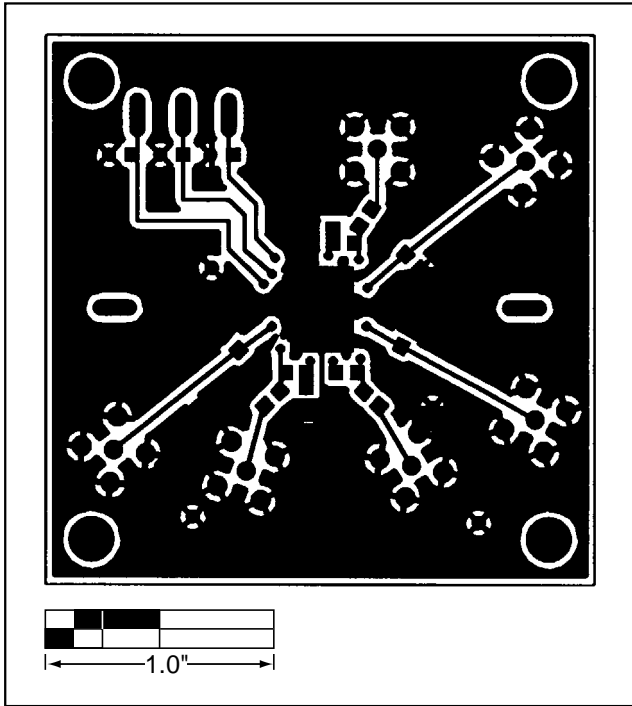

Figure 4. MAX4188 EV Kit PC Board Layout—Solder Side

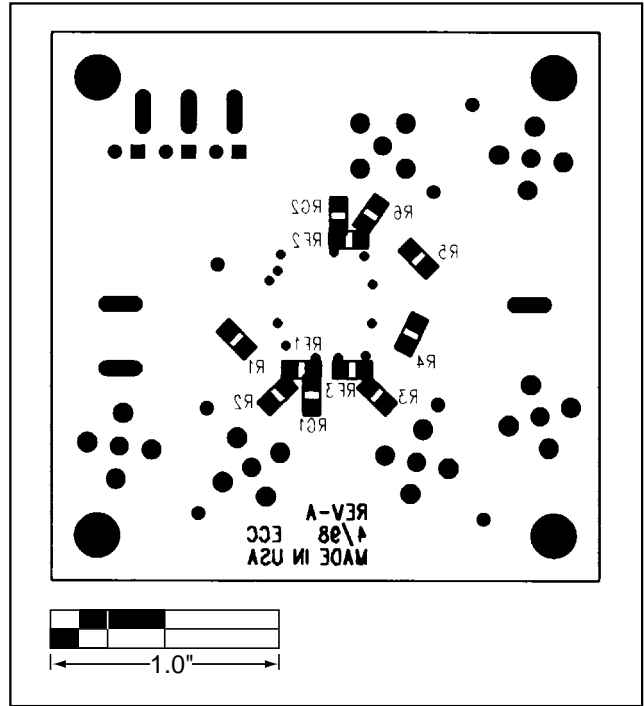

Figure 5. MAX4188 EV Kit Component Placement Guide—Solder Side

Maxim cannot assume responsibility for use of any circuitry other than circuitry entirely embodied in a Maxim product. No circuit patent licenses are implied. Maxim reserves the right to change the circuitry and specifications without notice at any time.

4 _____ Maxim Integrated Products, 120 San Gabriel Drive, Sunnyvale, CA 94086 408-737-7600